

**20% More**  
Slew limiting distortion

Explorations around a schematic found among old papers of mysterious origin, suspiciously similar to a datasheet sq/tri oscillator.

All that was needed was to connect the dots.

**SLEW LIMITER CORE**

A slew limiter smoothes out how quickly incoming voltage can change, limiting it to a fixed v/sec. slope. Since time and frequency are intrinsically linked, this acts as a steep, somewhat distorted low pass filter.

When it resonates (FEED), these fixed slopes become triangle wave oscillations, giving 20% more its unique sound. Your input signal can overwhelm this oscillation, making for pseudo-wavefolding and synthetic distortion artifacts.

This topology can result in quite a dark sound when SLEW is low, as there will not be much harmonic content present beyond the cutoff frequency. You can use BLEND to mix in a square wave signal that can help bring back some higher harmonics.

**LOW PASS GATE**

20% More has a slightly resonant, 2 pole, 12dB/oct low pass filter at its output. It offers a nice counterbalance to the grit of the slew limiter, and allows tasteful reigning in of the crackling potential present in the circuit.

**ENVELOPE FOLLOWER**

There is a simple internal envelope, its main purpose is to allow high feedback settings while avoiding (possibly unwanted) oscillations when no input is present. Both envelope destinations achieve this through different means.

When the envelope goes to the LPG, it is a bit like a sidechain input, where your playing dynamics open up the filter and let highs pass through, giving some nice springy west coast bongos; the LPG knob needs to be set low for the gating to be effective.

When the envelope goes to FEED, the average feedback is lowered slightly, loud playing will bring it back up. As loud inputs also fight the oscillations, interesting swashes of noise arise as your notes decay.

Play with INPUT. Interactions become intuitive.

**SUB OCTAVE**

20% More can route a squared version of the signal to one or two flip-flop based clock dividers, giving sub-octave and sub-sub-octave effects. It is only heard when BLEND is up somewhat. The sub octave is summed through diodes, giving it a characteristic 75% pulse.

**FULL WAVE RECTIFIER**

Envelope following requires a strictly positive input voltage. To achieve this, a full wave rectifier circuit is used. It is repurposed in the audio path as a switchable octave up. This particular implementation squishes very hard when INPUT is beyond noon. Enjoy.

**CONTROLS**

- INPUT**  
'mu amp' jfet preamp, lots of gain
- BLEND**  
mixes in a square wave / sub-octave copy of the signal
- VOLUME**  
output volume, gets very loud
- SLEW**  
slew limiter frequency
- FEED**  
slew limiter feedback
- LPG**  
low pass filter
- D - OCTAVE DOWN**  
clock division of the blended square wave, -1 or -2 oct
- U - OCTAVE UP**  
analog octave up, full wave rectifier
- E - ENVELOPE DESTINATION**  
routing of the internal envelope either added to the (L)PG or (F)EED controls

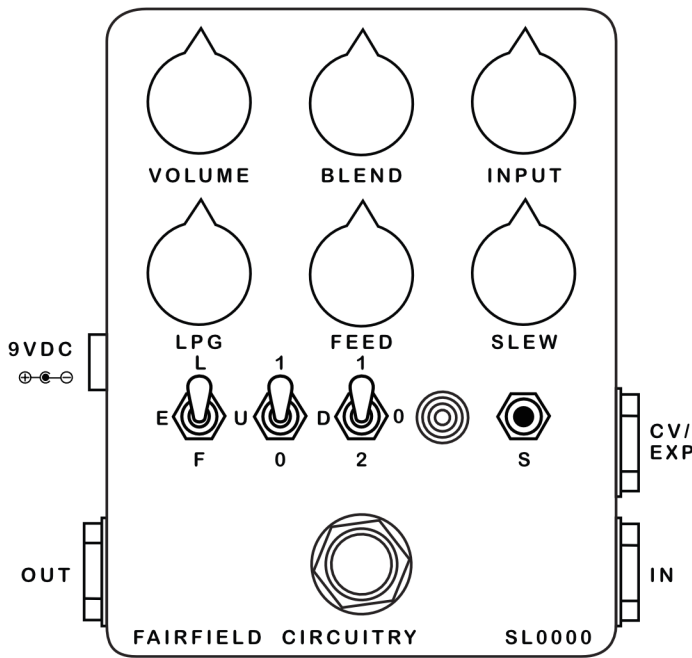

"Nothing exists but thoughts. The universe is composed of impressions, ideas, pleasures and pains."

**CONNECTIONS**

- IN**  
1/4" instrument or line input
- OUT**  
1/4" output
- CV**  
versatile 1/4" TRS CV/Exp port, see programming guide
- S**  
1/8" input  
CV over slew limiter frequency, v/oct
- 9VDC**  
2.1mm centre negative tip, 20 mA (sags quite well)

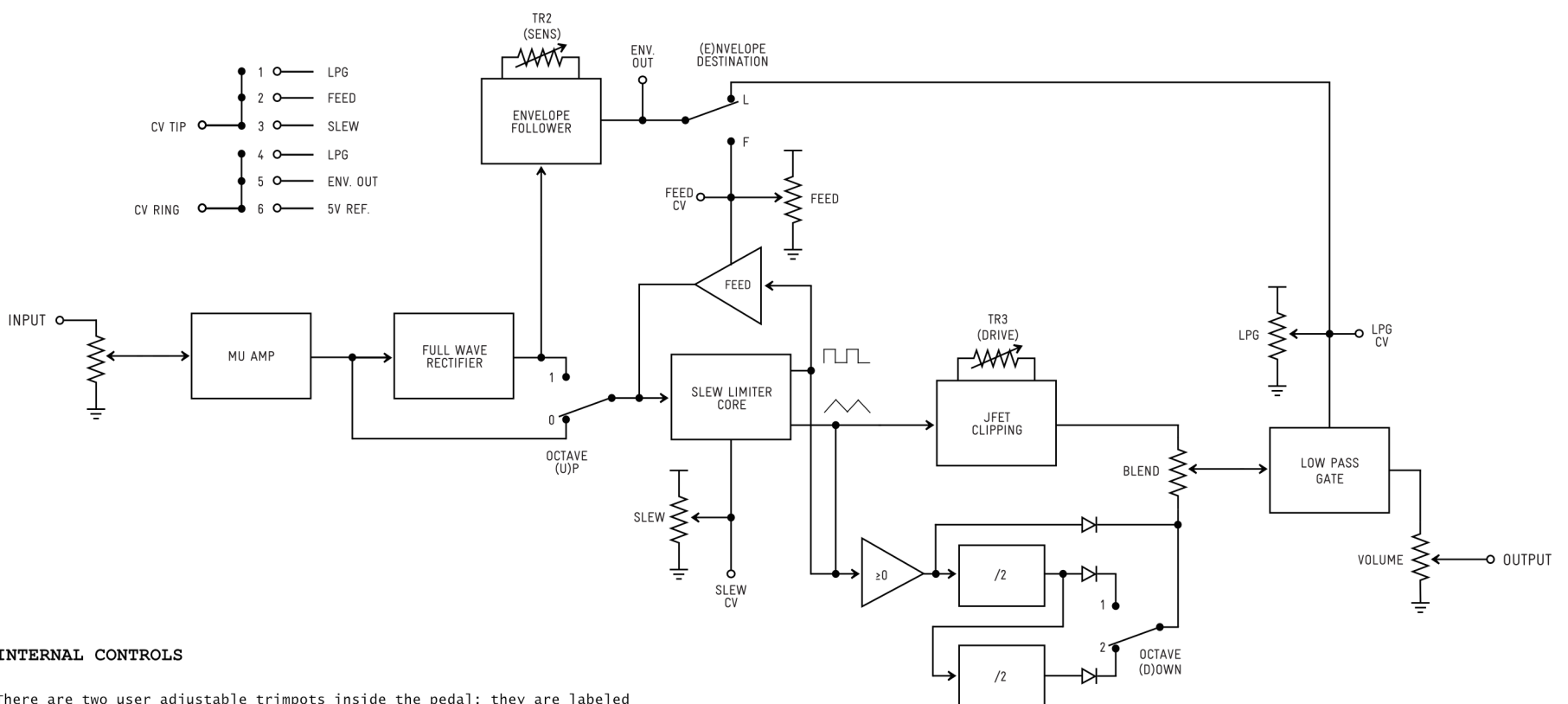

**INTERNAL CONTROLS**

There are two user adjustable trimpots inside the pedal; they are labeled TR3 (drive) and TR2 (sens). The two other trimmers set the jfet bias and v/oct calibration, they should not be adjusted by the user.

**DRIVE**

Sets the amount of signal going into the JFET clipping stage, another 20% more?

**SENS (ITIVITY)**

Sets the gain of the internal envelope, allowing you to attenuate or exaggerate the response to your playing dynamics.

**NOTES ON POWERING**

20% More was designed to operate using your typical centre negative, regulated 9 VDC power supply. The pedal is protected against reversed polarity conditions.

Always check your power supply for proper voltage and polarity before connecting. There is no battery connection inside the pedal.

**TECHNICALS**

- dimensions 4.7" x 3.8" x 1.9"
- CV input range 0 - 5V normal ; 0 - 8v max
- power supply 9VDC
- current draw 20 mA @ 9.6 VDC

**EXTENDED WARRANTY**

Fairfield Circuitry will repair or replace any malfunctioning product for a period of 2 years after purchase date. Problems resulting from modifications or misuse may cancel this warranty. The owner will cover all shipping expenses.

In short, the best thing to do is to contact us as soon as possible with a description of the symptoms, even if the warranty is expired.

## Safety instructions

### Intended use

This device serves as an effects device for processing instrument signals. Any other use or use under other operating conditions is deemed improper and may result in injury or product damage.

No liability will be taken for harms resulting from improper use.



#### WARNING!

Possible hearing damage due to high volumes on speakers, headphones, bass & guitar amplifiers!

With loudspeakers or headphones connected, the device can produce volume levels that may cause temporary or permanent hearing impairment.

Over an extended period, even levels that seem to be uncritical can cause hearing damage. Do not operate the device permanently at a high-volume level.

Decrease the volume level immediately if you experience ringing in your ears or hearing impairment and seek medical advice.



#### WARNING!

Choking hazard!

Ensure that packaging is properly disposed of and is not in the reach of babies or young children. Ensure that children do not detach any small parts (e.g. knobs or the like). They could swallow the pieces and choke.

Never let children use electrical devices unattended.

## Environmental information



For the transport and protective packaging, environmentally friendly materials have been chosen that can be supplied to normal recycling. Do not just dispose of these materials with your normal household waste, but make sure they are collected for recycling. Please follow the notes and markings on the packaging



This product is subject to the European Waste Electrical and Electronic Equipment Directive (WEEE) in its currently valid version. Do not dispose of your old device with your normal household waste. Dispose of this product through an approved waste disposal firm or through your local waste facility. Comply with the rules and regulations that apply in your country. If in doubt, consult your local waste disposal facility or contact us for retrieval of the product.

Les matériaux d'emballage sont recyclables.  
Points de collecte sur [www.quefairemesdechets.fr](http://www.quefairemesdechets.fr)

Privilégiez la réparation ou le don de votre appareil.



## Directives and regulations



This product complies with Electromagnetic Compatibility (EMC) directive 2014/30/EU.



Fairfield Circuitry has conformed where applicable to European Union's Directive 2011/65/EU on Restrictions of Hazardous Substances (RoHS) as well as the following sections of California law which refer to RoHS, namely sections 25214.10, 25214.10.2, and 58012, Health and Safety Code; Section 42475.2, Public Resources Code.



This product complies with the regulations required to hold the UKCA mark

## Fairfield Circuitry

73 boulevard St-Joseph,  
Gatineau, Québec, Canada  
J8Y 3G8

[info@fairfieldcircuitry.com](mailto:info@fairfieldcircuitry.com)