

SHALLOW WATER

K-Field Modulator

ABSTRACT

Shallow Water's essence could be characterized as uncertain, subtle and nostalgic.

Practically, this describes an effect built around your typical analogue chorus/vibrato circuit wherein the signal is delayed by a few dozen milliseconds using a bucket brigade device. Another signal then modulates this delay time to create changes in pitch, called vibrato. Chorus is achieved by mixing the original signal with the delayed signal, creating the moving comb filters that tickle our ears and feather our bangs.

Still, major differences can be noticed when studying the k-field modulator's architecture. The most striking are how the delay time is modulated in a random fashion and how the recovery filter moves in relation to the input signal.

Both these differences place Shallow Water in a category of its own, appropriately called k-field modulators.

As the present gets lost, the future becomes the past.

PSEUDO RANDOM GENERATOR

The random quality of the modulation begins in a simple program residing on a microcontroller. Its output resembles steps of random voltages, separated by random time intervals. The RATE control effectively sets the overall range of these time intervals.

INTEGRATOR AND DEPTH

These random stepped voltages are processed through a filter/integrator, giving control over the slope at which the steps will reach their new values. As DAMP is increased, the random steps become slow and sluggish, instead of sharp and abrupt. DEPTH defines the amount of modulation that will be used to modulate the time delay of our input signal. There is a strong interaction between all three controls affecting modulation; that is, RATE, DAMP and DEPTH.

VELOPE FOLLOWER AND RECOVERY FILTER

Once the input signal has passed through the delay line, a recovery filter and some kind of gate is necessary to remove unwanted noise generated by the bucket brigade device. To achieve this, the input's envelope is followed and used to modulate the frequency of a low pass filter. The amount of envelope is set by the LPG control, yielding bouncy, lo-fi responses to quick and snappy gate-like behaviours.

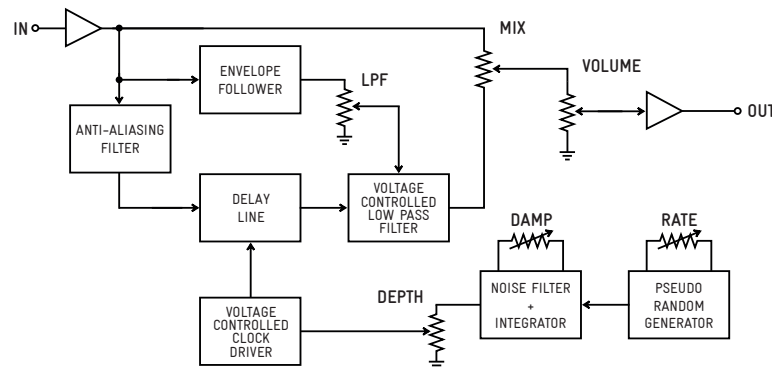

PHYSICALS

- 1/4" mono input/output jacks
- 2.1mm DC connector
- 4.7" x 3.8" enclosure dimensions

TECHNICALS

- true bypass
- input impedance 1M Ω
- output impedance 2k Ω
- power supply 9 to 9.6 VDC
- current draw 40 mA max.

NOTES ON POWERING

Shallow Water was designed to operate using your typical centre negative, regulated 9-9.6 VDC power supply. The pedal is protected against reversed polarity and overvoltage conditions. Always check your power supply for proper voltage and polarity before connecting. There is no battery connection inside the pedal.

EXTENDED WARRANTY

Fairfield Circuitry will repair or replace any malfunctioning product for a period of 2 years after purchase date. Problems resulting from modifications or misuse may cancel this warranty. The owner will cover all shipping expenses. This warranty applies only to original owner of the product. Proof of purchase might be required.

In short, the best thing to do is to contact us as soon as possible with a description of the symptoms, even if the warranty is expired.

CONTROLS

RATE

The RATE control adjusts the time intervals at which the random pitch fluctuations occur. From rare to nervous, the range is quite wide. At high RATE and DAMP settings, the quick variations have trouble passing through the swampy filter and integrator, effectively reducing perceived modulation. This is normal. The interaction between these two knobs is particular and needs to be tamed through experimentation.

DAMP

The DAMP control affects the slope of the modulating signal. At its minimum, the pitch modulations are quick and sudden; the random changes in modulation voltage are almost instantaneous. Increasing DAMP will elongate and soften the modulation. At high DAMP settings, the changes become so slow that they are not heard as pitch modulations. To hear the changes, some dry mix needs to be applied. Then, the slow movement of the delay time can be heard as chorus.

DEPTH

The DEPTH knob adjusts the intensity of the modulation. The interaction between all three modulation controls is noticeable. The range of modulation is focused towards subtle variations. Adjust to taste, though less is more.

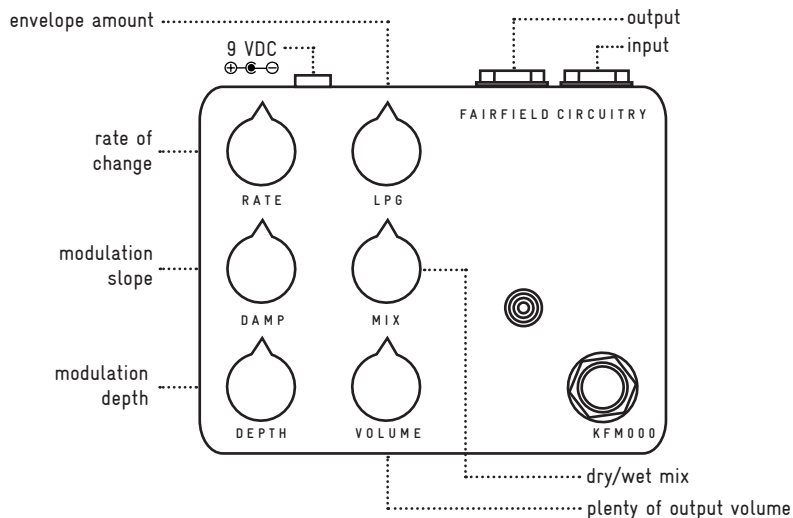

LPG

The LPG control adjusts the level of the envelope going to the low pass filter and gate circuit. At lower levels the signal will be darker, choke subtle notes and reduce sustain. At higher settings, the sound will be brighter, have more sustain and might reveal some noise produced by the bucket brigade device.

MIX

The MIX control balances between the dry and wet signal. When it's full wet (clockwise) the effect is like a vibrato. Chorus-type sounds are achieved by adding some of the dry signal (counter clockwise).

VOLUME

The VOLUME knob controls the output volume. Unity is around noon and beers around 5 at my place.

MORE CONTROL INSIDE

BOOST AND PAD

There are 2 jumpers at the input stage to match your input signal's level and impedance. By default, BOOST is on, PAD is off; a typical setting for high impedance, low output signals like a guitar's single coil pickups. If the user finds there is too much distortion at the input stage, moving the BOOST jumper to its off position will reduce overall gain by 6 dB. If the signal source is line-level, the PAD can be set to its on position, giving another 6 dB of gain reduction while also reducing the input impedance by a factor of 10.

LPG ADJUST

The recovery filter's lowest frequency can be adjusted, to fine tune the way it will react to incoming signals. Lowering this frequency emphasises the action of the low pass filter, effectively raising the threshold of sensitivity. Adjustment should be made with the following settings: MIX full wet, LPG minimum, DEPTH minimum. While listening to a signal going through the pedal, you'll hear the effect of the recovery filter at its resting state. Carefully turn the trimpot labelled LPG adjust, clockwise to raise the filter's frequency, counter-clockwise to lower. Be very careful, adjustments should be minimal as the trimpot is very sensitive. After each adjustment, LPG should be turned up momentarily to listen at the envelope's response to the incoming signal.



FAIRFIELD
• CIRCUITRY •

UNIQUE & ROBUST

MADE IN HULL, QUÉBEC

FAIRFIELDCIRCUITRY.COM

Safety instructions

Intended use

This device serves as an effects device for processing instrument signals. Any other use or use under other operating conditions is deemed improper and may result in injury or product damage.

No liability will be taken for harms resulting from improper use.



WARNING!

Possible hearing damage due to high volumes on speakers, headphones, bass & guitar amplifiers!

With loudspeakers or headphones connected, the device can produce volume levels that may cause temporary or permanent hearing impairment.

Over an extended period, even levels that seem to be uncritical can cause hearing damage. Do not operate the device permanently at a high-volume level.

Decrease the volume level immediately if you experience ringing in your ears or hearing impairment and seek medical advice.



WARNING!

Choking hazard!

Ensure that packaging is properly disposed of and is not in the reach of babies or young children. Ensure that children do not detach any small parts (e.g. knobs or the like). They could swallow the pieces and choke.

Never let children use electrical devices unattended.

Environmental information



For the transport and protective packaging, environmentally friendly materials have been chosen that can be supplied to normal recycling. Do not just dispose of these materials with your normal household waste, but make sure they are collected for recycling. Please follow the notes and markings on the packaging



This product is subject to the European Waste Electrical and Electronic Equipment Directive (WEEE) in its currently valid version. Do not dispose of your old device with your normal household waste. Dispose of this product through an approved waste disposal firm or through your local waste facility. Comply with the rules and regulations that apply in your country. If in doubt, consult your local waste disposal facility or contact us for retrieval of the product.

Les matériaux d'emballage sont recyclables.
Points de collecte sur www.quefairemesdechets.fr

Privilégiez la réparation ou le don de votre appareil.



Directives and regulations



This product complies with Electromagnetic Compatibility (EMC) directive 2014/30/EU.



Fairfield Circuitry has conformed where applicable to European Union's Directive 2011/65/EU on Restrictions of Hazardous Substances (RoHS) as well as the following sections of California law which refer to RoHS, namely sections 25214.10, 25214.10.2, and 58012, Health and Safety Code; Section 42475.2, Public Resources Code.



This product complies with the regulations required to hold the UKCA mark

Fairfield Circuitry

73 boulevard St-Joseph,
Gatineau, Québec, Canada
J8Y 3G8

info@fairfieldcircuitry.com